

Write your name here

Surname

Other names

Edexcel Certificate

Centre Number

Candidate Number

**Edexcel
International GCSE**

--	--	--	--	--

--	--	--	--

Mathematics A

Paper 2F



Foundation Tier

Tuesday 15 January 2013 – Morning

Time: 2 hours

Paper Reference

**4MA0/2F
KMA0/2F**

You must have:

Ruler graduated in centimetres and millimetres, protractor, compasses, pen, HB pencil, eraser, calculator. Tracing paper may be used.

Total Marks

Instructions

- Use **black** ink or ball-point pen.
- **Fill in the boxes** at the top of this page with your name, centre number and candidate number.
- Answer **all** questions.
- Without sufficient working, correct answers may be awarded no marks.
- Answer the questions in the spaces provided
– *there may be more space than you need.*
- **Calculators may be used.**
- You must **NOT** write anything on the formulae page.
Anything you write on the formulae page will gain **NO** credit.

Information

- The total mark for this paper is 100.
- The marks for **each** question are shown in brackets
– *use this as a guide as to how much time to spend on each question.*

Advice

- Read each question carefully before you start to answer it.
- Check your answers if you have time at the end.

Turn over ►

P41037A

©2013 Pearson Education Ltd.

6/6/5/6/6/6/



PEARSON

International GCSE MATHEMATICS
FORMULAE SHEET – FOUNDATION TIER

Pythagoras' Theorem
 $a^2 + b^2 = c^2$

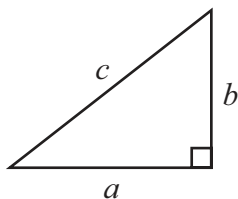

Area of a trapezium = $\frac{1}{2}(a + b)h$

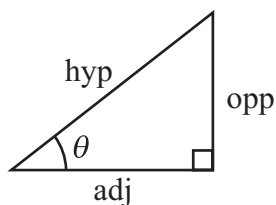
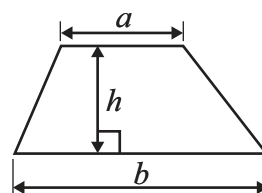

adj = hyp \times cos θ
opp = hyp \times sin θ
opp = adj \times tan θ

Volume of prism = area of cross section \times length

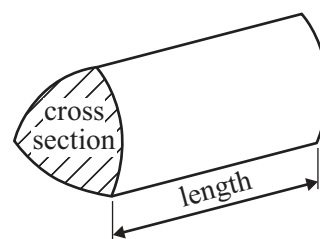

or $\sin \theta = \frac{\text{opp}}{\text{hyp}}$

$\cos \theta = \frac{\text{adj}}{\text{hyp}}$

$\tan \theta = \frac{\text{opp}}{\text{adj}}$

Circumference of circle = $2\pi r$

Area of circle = πr^2

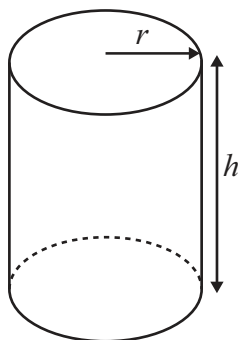

Volume of cylinder = $\pi r^2 h$

Curved surface area of cylinder = $2\pi r h$

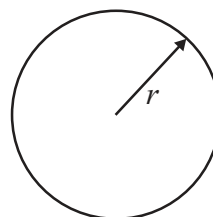

Answer ALL TWENTY EIGHT questions.

Write your answers in the spaces provided.

You must write down all the stages in your working.

1 (a) (i) What fraction of this shape is shaded?

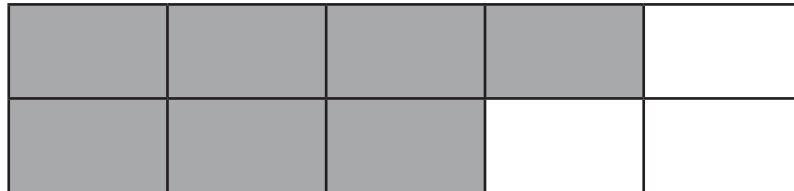

.....

(ii) Write your fraction as a decimal.

.....

(2)

(b) (i) Shade 25% of this shape.

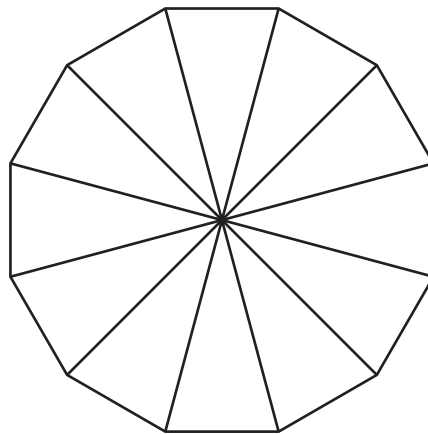

(ii) When 25% of the shape is shaded, what percentage is unshaded?





..... %

(2)

(Total for Question 1 is 4 marks)



- 2 The pictogram shows information about the number of goals scored by each of five countries in the 2010 football World Cup.

Holland	
Germany	
England	
Spain	
Portugal	
Ghana	

 represents 2 goals scored.

- (a) Which of the countries scored the greatest number of goals?

.....
(1)

- (b) Write down the number of goals scored by Holland.

.....
(1)

- (c) Which country scored 5 goals?

.....
(1)

- (d) Portugal scored 7 goals.

Show this information on the pictogram.

(1)



- (e) Find the ratio of the number of goals scored by Germany to the number of goals scored by Spain.
Give your ratio in its simplest form.

.....
(2)

(Total for Question 2 is 6 marks)

3

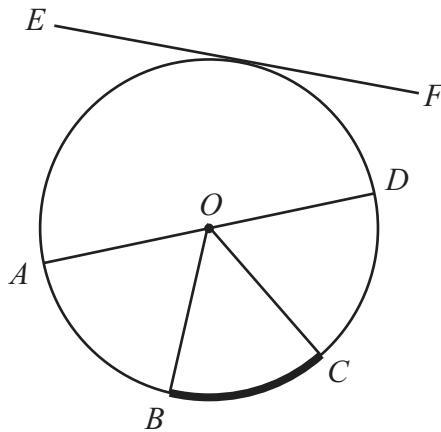

A, B, C and D are points on a circle, centre O .
The line EF touches the circle.

Write down the mathematical name for

- (i) the straight line AD ,

.....

- (ii) the part of the circumference of the circle between B and C ,

.....

- (iii) the straight line EF .

.....

(Total for Question 3 is 3 marks)



4 Here are the first five terms of a number sequence.

13 18 23 28 33

(a) Write down the next two terms of the sequence.

.....,

(2)

(b) Explain how you found your terms.

.....

(1)

(c) Work out the 18th term of the sequence.

.....

(1)

(Total for Question 4 is 4 marks)

5

10 11 12 14 16 18 20

From the numbers in the box, write down

(i) the odd number,

.....

(ii) the square number,

.....

(iii) the two factors of 48

.....,

(Total for Question 5 is 4 marks)



6 A 6-sided polygon is shown on a grid.

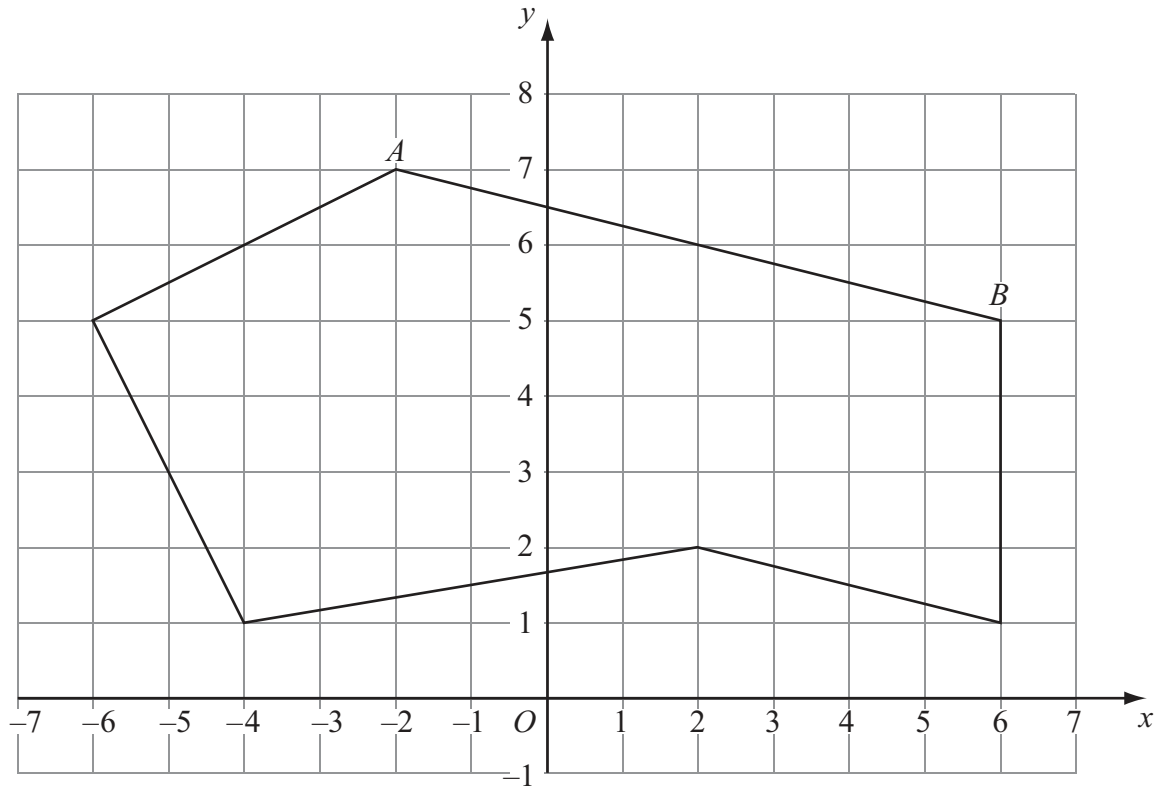

(a) Write down the mathematical name for a 6-sided polygon.

.....
(1)

(b) On the polygon, mark with arrows ($>$) a pair of parallel lines.

(1)

(c) On the polygon, mark with crosses (\times) a pair of perpendicular lines.

(1)

(d) Write down the coordinates of the point A .

(.....,)
(1)

(e) Find the coordinates of the midpoint of AB .

(.....,)
(2)

(Total for Question 6 is 6 marks)



7 (a) Work out 35% of 80

.....
(2)

(b) Work out $\frac{7}{8}$ of 48

.....
(2)

(Total for Question 7 is 4 marks)

- 8 The table shows information about the time in each of three cities.
For each city, it shows the number of hours time difference from the time in London.
+ shows that the time is ahead of the time in London.
– shows that the time is behind the time in London.

City	Time difference from London (hours)
Nairobi	+3
New York	–5
San Francisco	–8
Chicago	

(a) Work out the time difference between

(i) Nairobi and New York,

..... hours

(ii) New York and San Francisco.

..... hours

(2)

(b) The time in Chicago is 1 hour behind the time in **New York**.
Complete the table to show the time difference of Chicago from London.

(1)

(Total for Question 8 is 3 marks)



9 Here are nine mathematical symbols.



A



B



C



D



E



F



G



H



I

(a) Write down the letters of the two symbols which have 2 lines of symmetry and rotational symmetry of order 2

.....,
(2)

(b) Write down the letters of the two symbols which have no lines of symmetry and rotational symmetry of order 2

.....,
(2)

(c) Write down the order of rotational symmetry of symbol F.

.....
(1)

(Total for Question 9 is 5 marks)



10 There are 20 beads in a bag.
1 of the beads is blue.
The rest of the beads are either red or white.

Sharita takes at random a bead from the bag.

(a) Write down the probability that she will take

(i) a blue bead,

.....

(ii) a green bead.

.....

(2)

The probability that Sharita will take a red bead from the bag is $\frac{7}{10}$

(b) Find the probability that she will **not** take a red bead.

.....

(1)

(Total for Question 10 is 3 marks)

11 (a) Write these numbers in order of size.
Start with the smallest number.

$$\frac{4}{7}$$

$$\frac{5}{9}$$

0.58

56%

.....

(3)

(b) Show that $\frac{1}{6} \div \frac{1}{4} = \frac{2}{3}$

(2)

(Total for Question 11 is 5 marks)



12

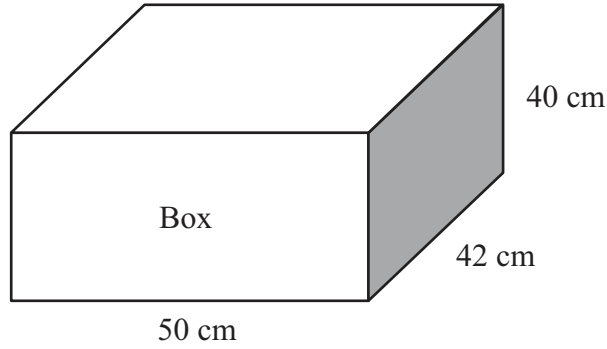
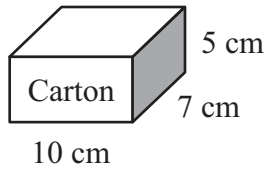

Diagram **NOT** accurately drawn

A carton measures 10 cm by 7 cm by 5 cm.
Cartons are packed into boxes.
A box measures 50 cm by 42 cm by 40 cm.

Work out the number of cartons needed to fill completely one box.

.....
(Total for Question 12 is 3 marks)

13

$$A = 5c - d$$

(a) Work out the value of A when $c = 1.6$ and $d = -2$

$$A = \text{.....}$$

(2)

(b) Work out the value of c when $A = 1$ and $d = 2$

$$c = \text{.....}$$

(3)

(Total for Question 13 is 5 marks)



- 14 The students in an international school were asked, "In which continent were you born?" Their answers were used to draw this pie chart.

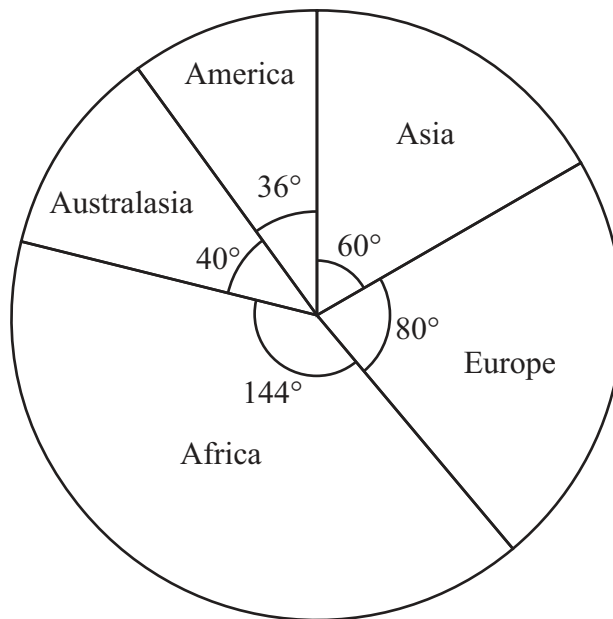

- (a) 90 students were born in Asia.

Work out the number of students who were born in Europe.

.....
(2)

- (b) The headteacher of the school chooses at random one of the students.

Find the probability that this student was born in Africa.

.....
(2)

(Total for Question 14 is 4 marks)



15

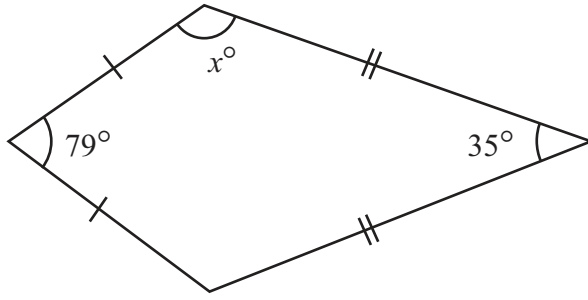

Diagram **NOT** accurately drawn

The diagram shows a kite.

Work out the value of x .

$x = \dots\dots\dots$

(Total for Question 15 is 3 marks)

16 (a) Use your calculator to work out the value of

$$\frac{8.7 + 2.8}{1.4^2}$$

Give your answer as a decimal.

Write down all the figures on your calculator display.

$\dots\dots\dots$
(2)

(b) Give your answer to part (a) correct to 2 significant figures.

$\dots\dots\dots$
(1)

(Total for Question 16 is 3 marks)



- 17 A circle has a diameter of 7.6 cm.
Work out the circumference of the circle.
Give your answer correct to 3 significant figures.

..... cm

(Total for Question 17 is 2 marks)

- 18 The table shows information about the marks of 20 students in a science test.

Mark	Frequency
6	2
7	4
8	5
9	8
10	1

Work out the mean mark of the 20 students.

.....

(Total for Question 18 is 3 marks)



19 $\mathcal{E} = \{\text{even numbers}\}$
 $A = \{2, 4, 6, 8, 10\}$

(a) B is a set such that $A \cap B = \{4, 8\}$
The set B has 3 members.

List the members of one possible set B .

.....
(2)

(b) C is a set such that $A \cap C = \emptyset$
The set C has 3 members.

List the members of one possible set C .

.....
(1)

(Total for Question 19 is 3 marks)

20 Solve $3x + 16 = 1 - 2x$
Show clear algebraic working.

$x = \dots\dots\dots$

(Total for Question 20 is 3 marks)

21 Abid is waiting for a bus.
The probability that his bus will be early is 0.2
The probability that his bus will be on time is 0.7

Work out the probability that his bus will be either early or on time.

.....
(Total for Question 21 is 2 marks)



22

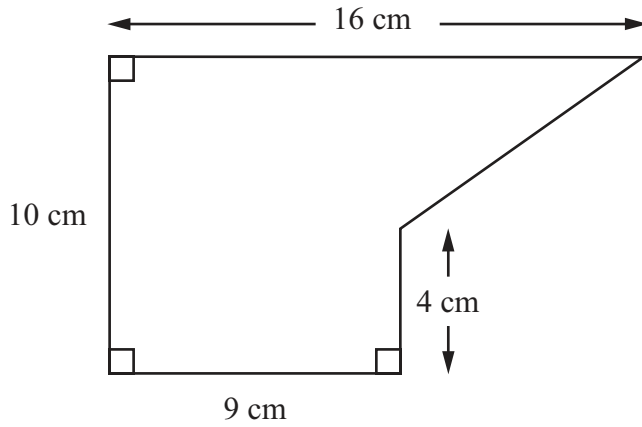

Diagram **NOT** accurately drawn

The diagram shows a shape.

Work out the area of the shape.

..... cm²

(Total for Question 22 is 4 marks)

23 (a) Expand and simplify $3(2x - 5) - 4(x + 3)$

.....
(2)

(b) Expand and simplify $(y + 7)(y + 2)$

.....
(2)

(Total for Question 23 is 4 marks)



24

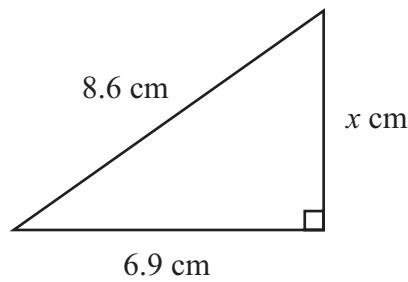

Diagram NOT
accurately drawn

Work out the value of x .
Give your answer correct to 3 significant figures.

$x = \dots\dots\dots$

(Total for Question 24 is 3 marks)

25 $\frac{5}{9}$ of the students in a group are male.

$\frac{5}{6}$ of the **female** students in the group are right-handed.

Work out the fraction of students in the group who are right-handed females.

$\dots\dots\dots$

(Total for Question 25 is 3 marks)

26 Jack, Kate and Lila share some money in the ratios 5 : 9 : 6
In total, Jack and Kate receive £56

Work out the amount of money Lila receives.

£ $\dots\dots\dots$

(Total for Question 26 is 3 marks)



27 Use ruler and compasses to construct the bisector of angle ABC .
You must show all your construction lines.

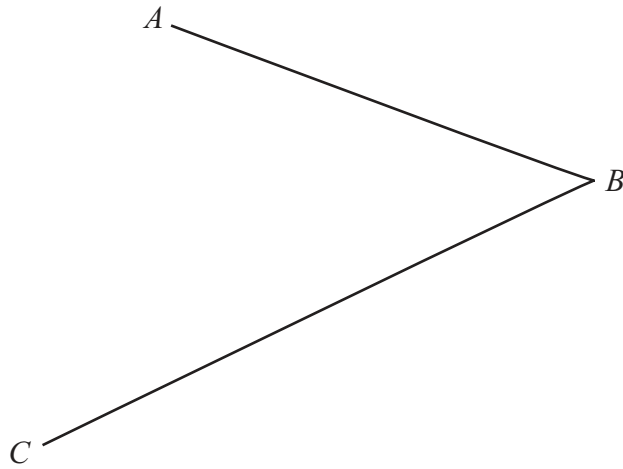

(Total for Question 27 is 2 marks)

28

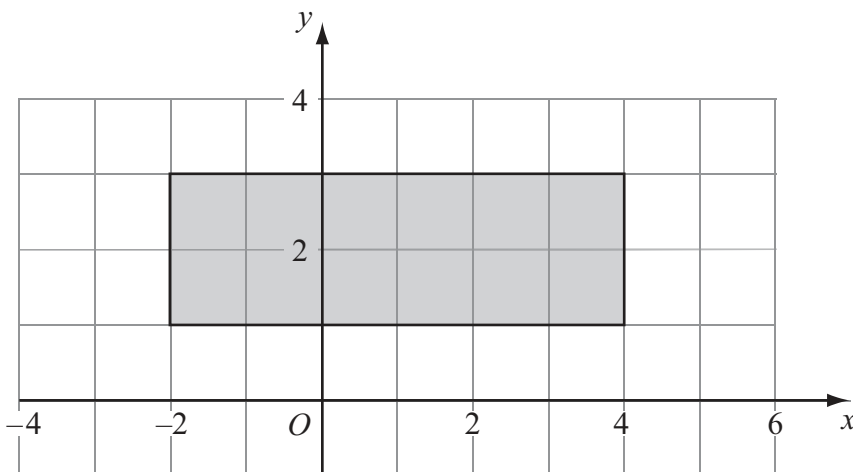

Write down inequalities to define fully the shaded region.

(Total for Question 28 is 3 marks)

TOTAL FOR PAPER IS 100 MARKS



BLANK PAGE

Do NOT write on this page.



BLANK PAGE

Do NOT write on this page.

